

## **RIGID AUTOCLAVABLE ENDOSCOPES**

### **Indications and Use**

Endoscopes are used for illumination and visualization for diagnostic and therapeutic endoscopic surgical procedures in the following areas:

Arthroscopy; Bronchoscopy; Hysteroscopy; Laparoscopy; Laryngoscopy; Esophagoscopy; Otoscopy; Sinuscopy; Thoracoscopy; Urethroscopy; Ureterorenoscopy; Ventriculoscopy; Cystoscopy; Spinal surgery.

The main goal of endoscopic diagnosis and endoscopic surgery lies in tissue saving and thereby an enhanced preservation of function.

In this users manual, no clinical applications are outlined or explained.

### **Side Effects / Contraindications**

#### **Infection Risk**

In endoscopic studies, the risk of infection is of particular importance.

The risk factor for an increased risk of infection are divided into two groups:

Process-related risks:

- The nature and extend of tissue damage in therapeutic procedures;
- Circumstances of the endoscopic surgery (emergency surgery or elective surgery);
- Expertise and experience of the examiner / user;
- Proper cleaning and disinfection of endoscopes and accessories.

Patient-related risks:

- Reduced immune status of patients or immunosuppression (HIV, Leukemia, Lymphoma, Immunosuppressive therapy, advanced liver or kidney disease, advanced age);
- Existence of specific infections or anatomical characteristics;
- Encouraging situations of body bacteria adhesion (heart valve defects, heart valve replacements, endoprostheses, an intravenous catheter).

In endoscopic procedures, there may be an endogenous movement of microorganisms with subsequent bacteraemia. In this regard, the national and international recommendations for the prophylactic administration of antibiotics before certain procedures are to be followed (ESGE Guidelines 1998)

### **Safe handling**

- Prepare a brand-new endoscope before initial use (unsterilized in delivery condition).
- Check the endoscope for sharp edges, bent, loose or broken components before each use.
- Check the endoscope for correct function and for damage after each preparation.

- Segregate damaged endoscopes immediately.
- When using the endoscope in a trocar, avoid bending/pressure during insertion and withdrawal.
- Semi-flexible endoscopes are designed for minor flexural loads.  
A deflection of the tubing is admissible up to max. 20°!

Higher bending forces cause permanent deformation and damage of the product.

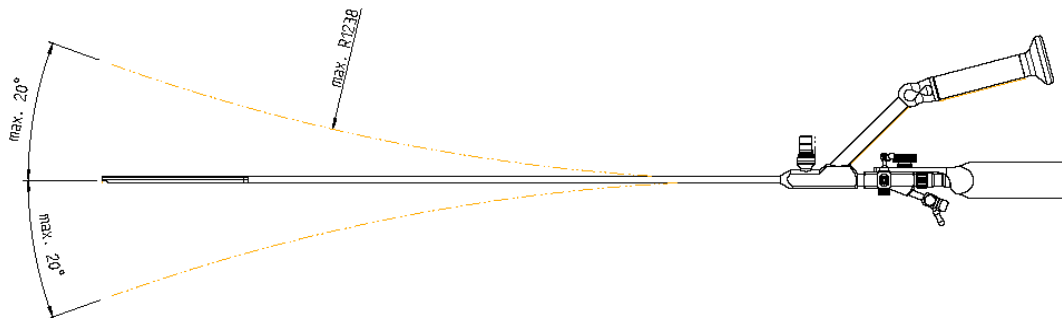

- Endoscopes may only be used by physicians or by medical personnel under the supervision of a physician.  
Adequate training, knowledge and experience in the clinical application of endoscopic techniques is required.
- Read the instructions for use carefully and follow them in detail.

## **Visual and functional inspection**

Check for:

- external damage (shaft deformed, dents or sharp edges)
- cleaner or disinfectant residues
- condition of the three optical surfaces – 1. objective window, 2. ocular window, 3. light cable connection – using reflected light or magnifying glass (smooth, clean and undamaged)
- optimal image quality (sharp, bright and clear)
- loss-free light transmission from light cable connection to light output (compare with new device, if necessary)
- unobstructed working channels

## **Warnings and precautions**

- **During use, the distal end and the light cable connection can become very hot due to the emission of light and thermal energy. Avoid any direct contact with tissue and flammable materials. If possible, do not select the maximum illumination setting, but only the brightness level that is actually required.**



**Possible cause of burns!**



- **When operating with RF electrodes, ensure that the active electrode is always within the field of view and that there is no contact with the endoscope or other metal components of the instruments.**

**Possible cause of burns!**



- **In the case of laser surgery, do not use reflective objects in the working area and do not direct the laser beam towards endoscope.**

**Possible cause of burns!**



- **All endoscopes must be prepared according to the instructions for each use and application.**

**Possible cause of infection!**



- **Do not use damaged endoscopes (see section "Visual and functional inspection")**

**Possible cause of injury!**

**Note:**

**In case the endoscope is damaged during use, it is useful to have a second, sterile endoscope available as a replacement.**

**Material stability**

Cleaners and disinfectants can cause substantial damage to the endoscopes. They should not contain the following components:

- Oxidising agents
- Organic, mineral and oxidising acids (minimal permissible pH value: 5)
- Strong alkalis (maximum permissible pH value: 10)
- Phenols or halogens (e.g. chlorine, iodine, bromine)
- Aromatic/halogenated hydrocarbons

Cleaners or disinfectants used in combination must be compatible with one another. Neutral or slightly alkaline cleaners are recommended.

- Never accelerate the cooling process of endoscopes (e.g. with cold water); sudden temperature fluctuations can result in the destruction of optical components.

- Endoscopes must not be exposed to temperatures exceeding 137°C (279°F).
- Do not use abrasive cleaners, steel wool or metal brushes for cleaning purposes.
- Never clean endoscopes in ultrasonic baths (results in damage to the optical system).
- Do not use hot-air sterilisation, flash sterilisation or radiation sterilisation.

If the instructions for use are observed, the number of reprocessing cycles has little effect on the service life of the products.  
The durability of endoscopes depends mainly on the proper care, handling and use.

## **Assembly / Disassembly**



- **Take care when disassembling contaminated endoscopes.**

### **Possible cause of infection!**

## **Light cable connection**

### **Disassembly:**

- Unscrew adapter ① or ② from the endoscope
- On working channels – if present:
  - Detach sealing cap.
  - Unscrew valve body.
  - Remove valve.

### **Assembly:**

- Screw on adapter ① or ②.
- On working channels – if present:
  - Insert a new valve.
  - Screw on valve body.
  - Attach sealing cap.

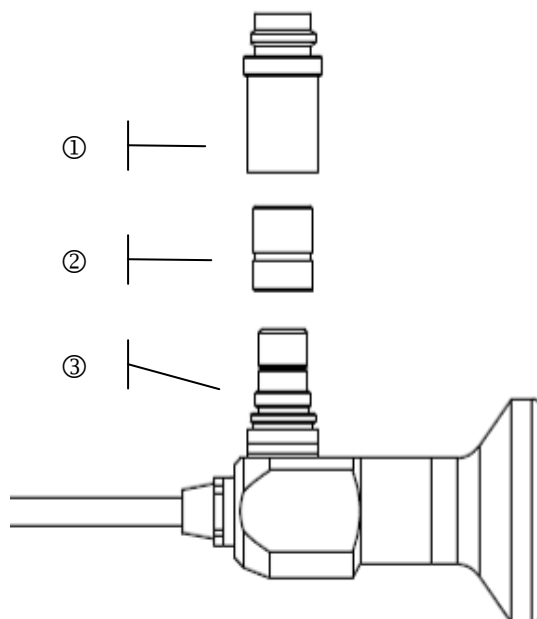

- ① Storz® / Aesculap® / Olympus®-adapter
- ② Wolf®-adapter
- ③ ACMI®-connection

## **Stop-cocks**

### **Disassembly:**

- Unscrew the spring cap ⑧ and remove the conical valve ⑦ from the stop-cock ⑥.

### **Assembly:**

- In order to protect against corrosion and to maintain operability, the conical valve ⑦ must be treated with a lubricant before each sterilisation.
- When inserting the conical valve, ensure that the guide pin engages in the guide and that the lever points towards the opening in open condition.
- Screw the spring cap ⑧ onto the conical valve ⑦.
- Check stop-cocks for correct functioning.

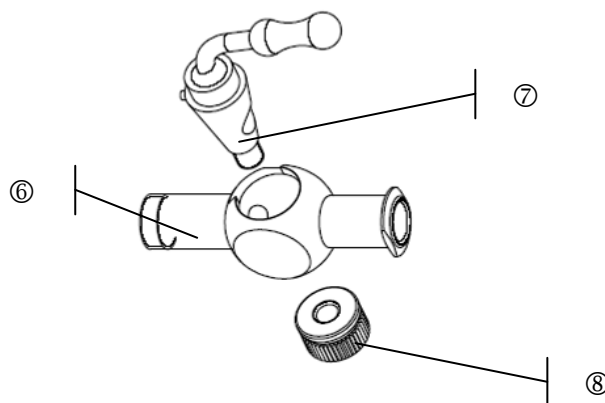

- ⑥ Stop-cock
- ⑦ Conical valve
- ⑧ Spring cap

## **Preparation (cleaning, disinfection and sterilisation)**

### **General requirements**

All endoscopes must be cleaned, disinfected and sterilised before each application. This applies in particular to brand-new optics, as all endoscopes are unsterilized when delivered (cleaning and disinfection following removal of the transport packaging; sterilisation in suitable sterilisation packaging). The following conditions are prerequisites for effective preparation:

- Determination of configurations for charging the used devices and observance of the relevant manufacturers instructions for use.



## Instructions For Use



- Regular maintenance and inspection of the used devices.
- Validated processes for all preparation steps.
- Conformance to standardised parameters for each preparation cycle.
- Checking disinfection and sterilisation efficiency using corresponding indicators.

Furthermore, the relevant applicable national hygiene regulations and the local medical practice or hospital guidelines must be observed, especially the various specifications regarding effective prion inactivation.

### **Cleaning and disinfection**

#### **Requirements**

The mechanical process in the cleaning and disinfection device described here should be used preferentially.

If an appropriate machine is not available, a manual process can also be used. However, the low effectiveness and reproducibility must be taken into account here. Furthermore, the manual cleaning and disinfection process must be assured under the responsibility of the user (additional product and process-specific standardisation).

Effective cleaning and disinfection are prerequisites for effective sterilisation.

Regardless, preparatory treatment must always be performed.

#### **Preparatory treatment**

Important tasks immediately after use:

- Remove all light cable adapters before preparation. Disassembly: all stop-cocks, if present (see section "Disassembly/Assembly of stop-cocks").
- Thorough rinsing with cold, running water (max. 20°C) in order to remove coarse contamination from the endoscopes.
- Remove stubborn contamination using a mild cleaning solution, which is approved for medical endoscopes (see section "Material stability")
- Do not use abrasive cleaners or metal brushes and avoid applying excessive force during the manual removal of contamination.
- Reassemble the stop-cocks, if present (see specific instruction) and flush out all working channels five times using a disposable syringe (minimum volume: 50 ml).
- Final rinsing of the endoscope with fully desalinated water to prevent formation of residue.
- Complete drying with compressed air (cavities) or a lint-free cloth.

## **Warnings and precautions**



- Use only those cleaning products that have been tested according to the national public health and local guidelines.

### **Possible cause of infection!**



- For endoscopes with instrument channels (irrigation and working channel) the inner lumen should be carefully cleaned and disinfected to avoid the fixation and preservation of organic residues by aldehydes.

### **Possible cause of infection!**

## **Mechanical cleaning and disinfection**

### **Prerequisites for suitable cleaning/disinfection devices:**

- Choose selection for optimal endoscope cleaning with sufficient cleaning cycles.
- Controlled programme for thermal disinfection (A0 value > 3000 or at least 5 minutes at 90°C) with proven effectiveness.
- Regular maintenance and verified effectiveness (e.g. DGHM or FDA approval or CE mark certification according to DIN EN ISO 15883).
- Final rinsing with water that is sterile or of low microbiological contamination (max. 10 bacteria/ml) and low in endotoxins (max. 0.25 endotoxin units/ml) (e.g. purified water/highly purified water).
- Controlled drying phase.

With chemo-thermal disinfection, there is a risk of disinfectant residues on the endoscopes.

### **Prerequisites for suitable cleaners and disinfectants:**

- Approval for the cleaning of endoscopic instruments with verified effectiveness (e.g. DGHM or FDA approval or CE mark certification)
- Compatibility of cleaners/disinfectants with one another (especially with chemo-thermal disinfection).
- Listed chemicals (see section "Material stability") should not be present.
- Use an enzyme-based agent with neutral pH value.

An increased chloride concentration in the tapwater circuit can result in material damage (pitting corrosion). The rinsing water must be prepared in such way that recontamination with bacteria is avoided. The manufacturer's specifications regarding concentration, temperature and exposure time for the cleaners and disinfectants must be observed.

### **Process:**

1. Securely fasten the endoscopes to the inserts of the disinfection device. Prevent impairment of rinsing and contact between the endoscopes and other instruments.
2. Open the stop-cocks (if present) and connect all endoscope channels to the special inserts with rinsing device.
3. Do not overload the disinfection device.
4. Start the programme.



## Instructions For Use

GB

5. Remove the endoscope from the disinfection device immediately after completion of automatic cleaning, in order to prevent corrosion, avoid accelerated colling (e.g. water).
6. Inspection and maintenance (see separate sections).
7. Packaging of endoscopes (see section "Packaging").

*Proof of the basic suitability of the endoscopes for effective mechanical cleaning and disinfection was provided by an independent accredited testing laboratory, using the G 7836 GD disinfectant (thermal disinfection, Miele & Cie. GmbH & Co., Gütersloh) and Neodisher mediclean cleaner (Dr. Weigert GmbH & Co.KG, Hamburg). The above-described process was observed for this purpose.*

## **Other methods for cleaning and disinfection**

### **Steris Per-Acetic Acid Disinfection**

The endoscopes were successfully tested for the basic stability of the used materials using per-acetic acid process (**STERIS-System 1**).

However, utilisation is only permitted if this process is approved for your facility in your country and the effectiveness has been proven by the user within the scope of a product/geometry/material process and device specific qualification, taking account of EN ISO 15883 specifications (including basic suitability of device and process) and, if necessary, supplementation through additional effective processes has occurred.

Use the above-described preparation processes preferentially to minimize risks.

## **Inspection**

- Before each sterilisation, the endoscope must be assembled and inspected (see section "Assembly instructions" and "Visual and functional inspection").
- Visual inspection of the three optical surfaces (see section "Visual and functional inspection").
- Examination of corrosion, wear, sharp edges or cracks in the distal area.
- Segregate damaged endoscopes.

## **Maintenance**

- The stop-cocks must be lubricated following each cleaning and each sterilisation (see section "Disassembly/assembly of stop-cocks").
- Only lubricants which have verified bio-compatibility may be used. The lubricant must be suitable for this application and must be approved for steam sterilisation.
- Regular cleaning of the optical surfaces with 70% alcohol (ethanol, isopropanol) prevents build-up of deposits.



## **Packaging**

- Open all stop-cocks, if present.
- Use only disposable sterilisation packaging and/or sterilising containers which are suitable for steam sterilisation (adequate temperature resistance, air and steam permeability - DIN EN ISO/ANSI AAMI ISO 11607).
- The packaging must ensure optimal protection of the sterile endoscopes during transport and storage.
- Reusable sterilising containers must be maintained in accordance with manufacturer's specifications. The endoscopes must be fixed securely in the containers and protected against damage.

As the suitability of the packaging considerably influences the sterilisation results, this should have been checked within the process and determination of sterilisation parameters.

## **Sterilization**

The following sterilisation processes have been validated for their germicidal effect on the endoscopes.

### **Steam sterilization**

- Fractionated vacuum process (with pre-vacuum) for endoscopes with and without working channel.
- Gravitation process, only for endoscopes without working channel.

### **Conditions for steam sterilisation**

- Sterilisation temperature: max. 134°C (273°F); plus Tolerance according to DIN EN ISO 17665 (formerly DIN EN 554/ANSI AAMI ISO 11134).
- Sterilisation time at sterilisation temperature: At least 5 minutes at 132°C (270°F)/134°C (273°F) and 2.3 bar, or 18 minutes (prion inactivation).
- Steam steriliser according to DIN EN 13060 or DIN EN 285 and tested according to DIN EN ISO 17665 (formerly DIN EN 554/ANSI AAMI ISO 11134).
- Observe cooling time. Accelerated cooling (e.g. with cold water) can result in the destruction of the endoscopes.

*Proof of the suitability of the endoscopes for the effective steam sterilisation was provided by an independent testing laboratory, using the Systec V-150 steam steriliser (Systec GmbH Labor- Systemtechnik, Wettenberg) and the fractionated vacuum process as well as the gravitation process. For this purpose, typical conditions in clinics and in medical practice as well as the above-described process were taken into account.*

## **Other sterilization methods**

The endoscopes were successfully tested in the low-temperature plasma process (**STERRAD System 100S, 200, 50, NX, 100NX**) to the resistance of materials used and their microbiological effectiveness. The suitability of the endoscopes and the effectiveness of treatment have been shown in laboratory tests using the above systems. Endoscopes with narrow-lumen cavities must be sterilized using Diffusion amplifiers. Application-specific instructions and compatibility manuals may be obtained directly from **Advanced Sterilization Products® (ASP)**.



The data relating to the sterilizer preparation, packing and implementation of the sterilization process must be observed carefully.

### **Gas sterilization**

The endoscopes were successfully tested for the basic stability of the used materials using Ethylenoxid-process.

However, utilisation is only permitted if this process is approved for your facility in your country and the effectiveness has been proven by the user within the scope of a product/geometry/material process and device specific qualification, taking account of EN ISO 15883 specifications (including basic suitability of device and process) and, if necessary, supplementation through additional effective processes has occurred.

Further sterilisation processes are impermissible (see section "Material stability").

### **Storage**

Following sterilisation, store the endoscopes in a sterilising container or single/double sterile packaging until they are reused.

The storage location must be dust-free, of low microbiological contamination, dry, dark and free from temperature fluctuations.

### **Service**

A comprehensive repair and exchange program for endoscopes is being offered. Repairs may only be performed by the manufacturer or by authorized service facilities using original spare parts.

### **Hygiene**

For safety reasons, thoroughly clean, disinfect and sterilise defective endoscopes before returning them.

In case of contamination, we reserve the right to charge the customer for the cost of preparation.

### **Loss of warranty**

The use of damaged and/or contaminated endoscopes is the responsibility of the user. Disregarding these instructions for use will void the guarantee or warranty claims. We accept no liability in the case of improper handling, incorrect or inadequate preparation or unauthorized repairs.

**Amnotec International Medical GmbH**  
Take-off Gewerbepark 9  
78579 Neuhausen ob Eck

 Phone +49 / (0)7467/ 9493900  
 E-Mail [info@amnotec.de](mailto:info@amnotec.de)  
 Web [www.amnotec.de](http://www.amnotec.de)